

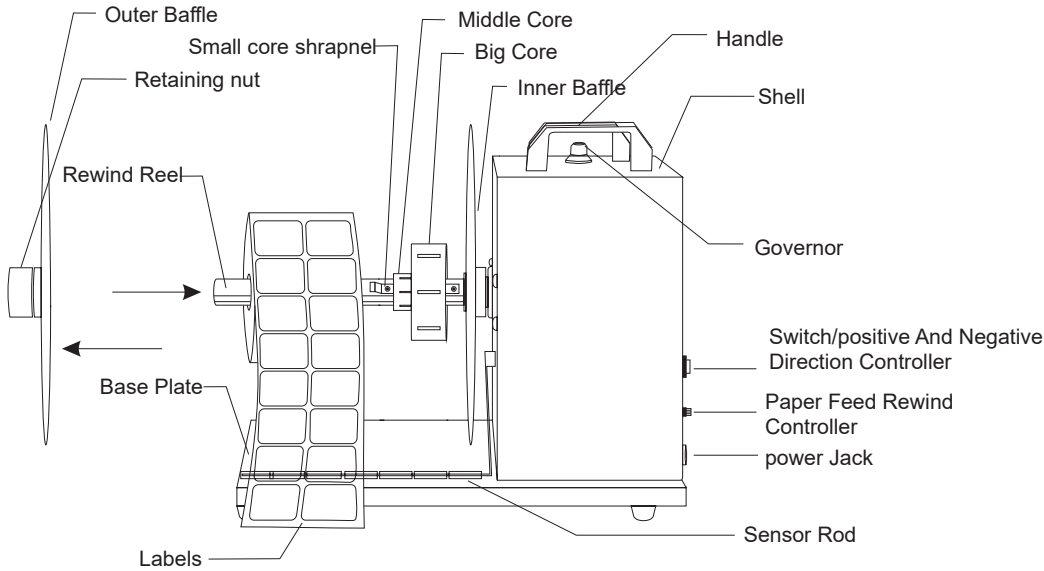

# BS-A230 Label Rewinder Installation & Operating Instructions

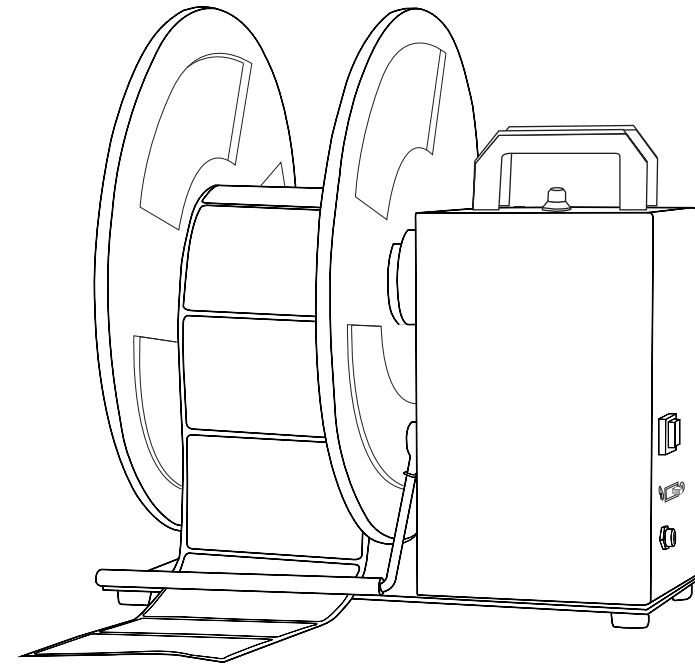

Label Rewinders, No need manual rewind when printing, Resolve trivial manual rewinding process, Reduce labour intensity, Improve label printing quality (labels stick dust easily or destroy if not rewind on time). It can help enterprises save labor cost, Promote working efficiency, Improve enterprise image, it is the good helper for the labeling personnel, Also it is the good partner for the boss.





## BS-A230 Label Rewinder Installation Diagram

